

ERGO 60

PCSCHEMATIC Automation

A/S WODSCHOW & Co.
Kirkebjerg Søpark 6
DK-2605 Brøndby, Denmark
www.bearvarimixer.dk



Project title: ERGO 60	Case no.:	Project rev.:	Page 1
Customer:			Scale: 1:1
Page title: front page	Dwg. no.:	Page rev.:	Previous page:
File name: 35.060-10.03.04_external_use	Eng. (proj/page): CE / CE	Last print: 22-12-2017	Next page: 2
Page ref.:	Appr. (date/init):	Last edit: 28-07-2017	Total no. of pages: 25

Documentation Info

This electrical documentation fits ERGO 60

- ENG. version
- UL approval
- 3P, 380-480V

Notes

There will be several variants of charts like this:

- 1: With and without brakes
- 2: With and without transformer
- 3: UL or CE approvals

Further, it should be noted that there will be some old versions which will be phase objections along the way, this problem will this be rectified.

Revision descriptions

PCSCHEMATIC Automation

A/S WODSCHOW & Co.

Kirkebjerg Søpark 6
DK-2605 Brøndby, Denmark
www.bearvarimixer.dk



Project title: ERGO 60	Case no.:	Project rev.:	Page 4
Customer:	DCC: &DB		Scale: 1:1
Page title: Diagram	Dwg. no.:	Page rev.:	Previous page: 3
File name: 35.060-10.03.04_external_use	Eng. (proj/page): CE	Last print: 22-12-2017	Next page: 5
Page ref.:	Appr. (date/init):	Last edit: 21-12-2017	Total no. of pages: 25

Diagram

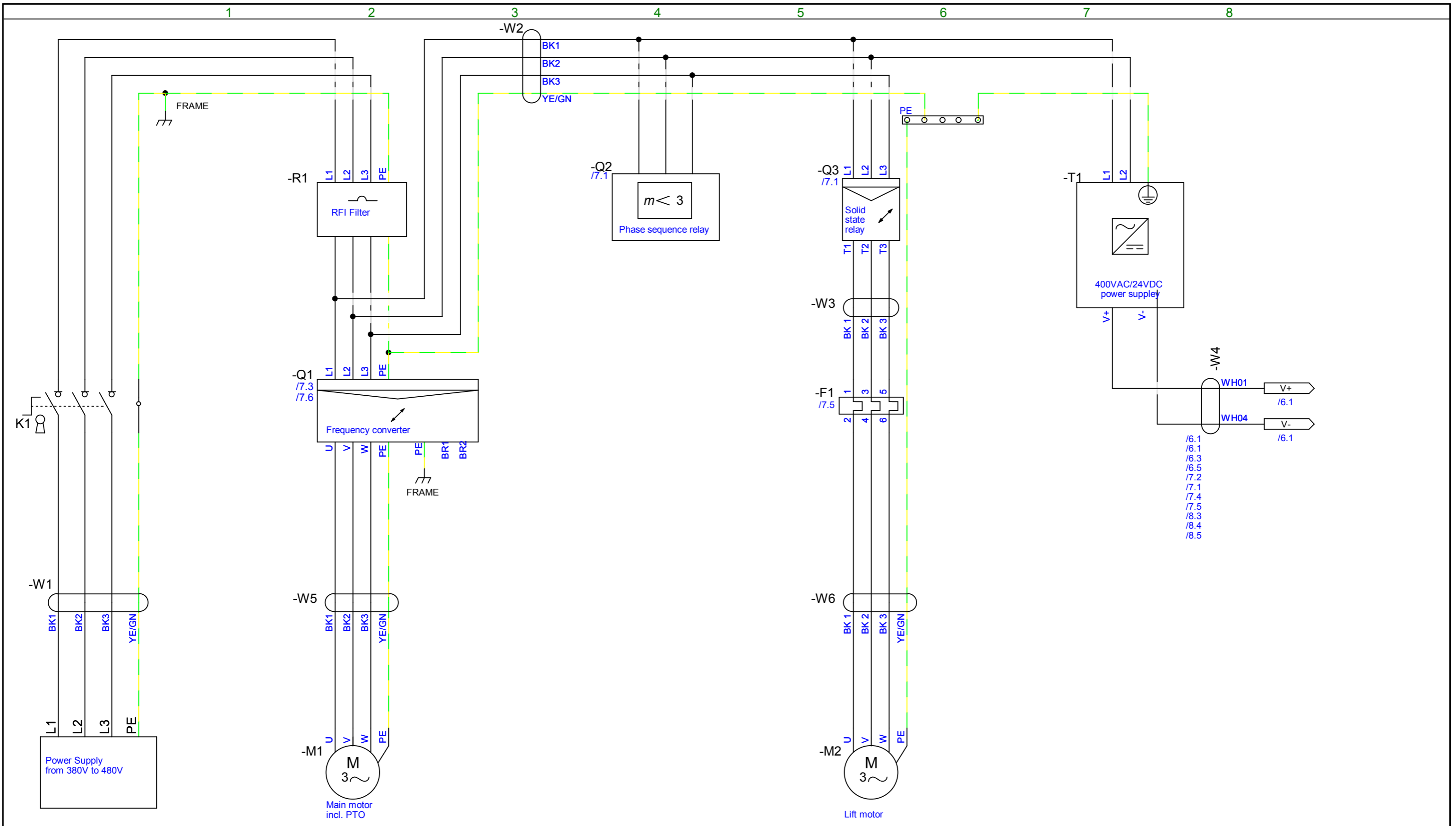

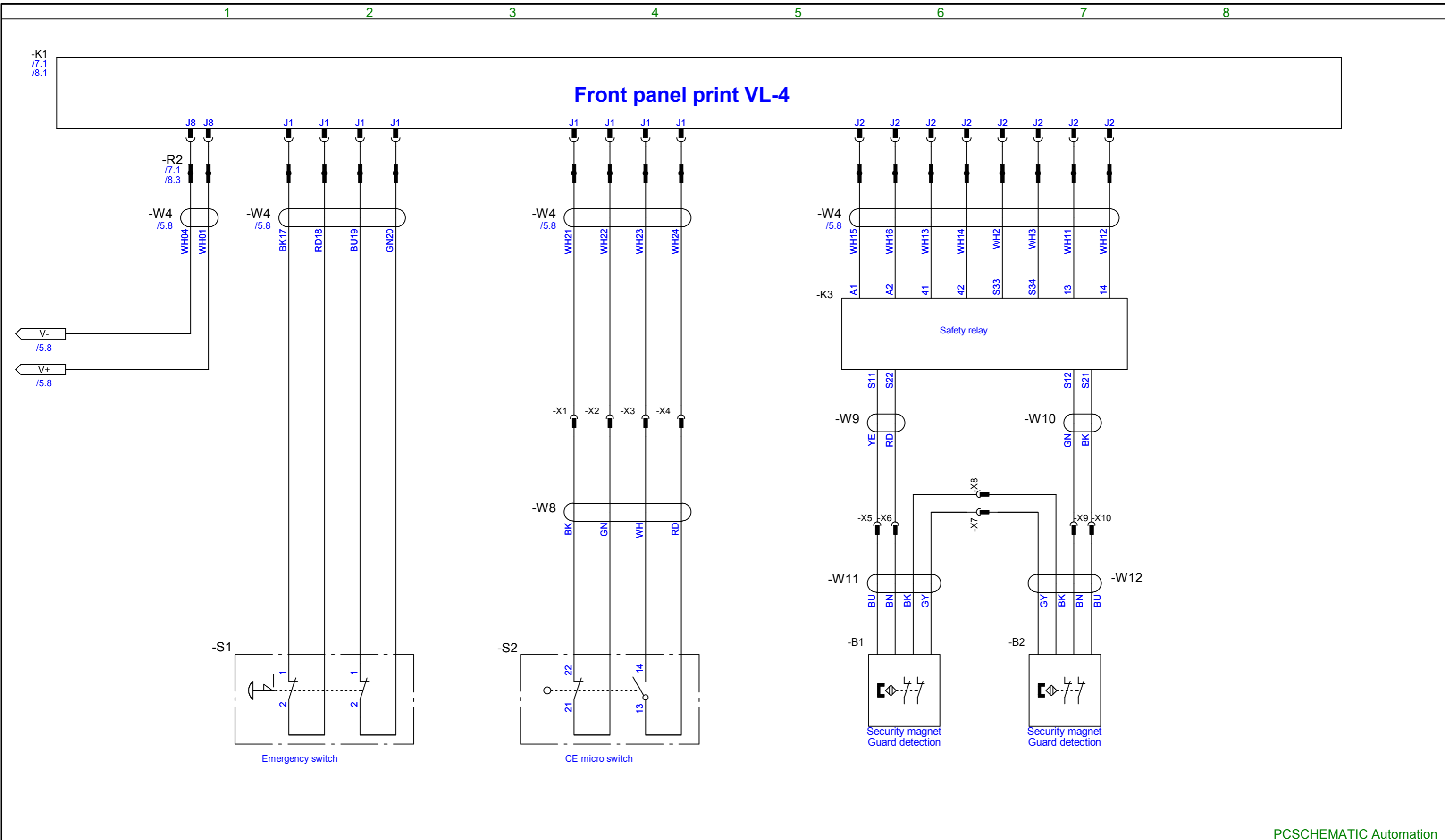

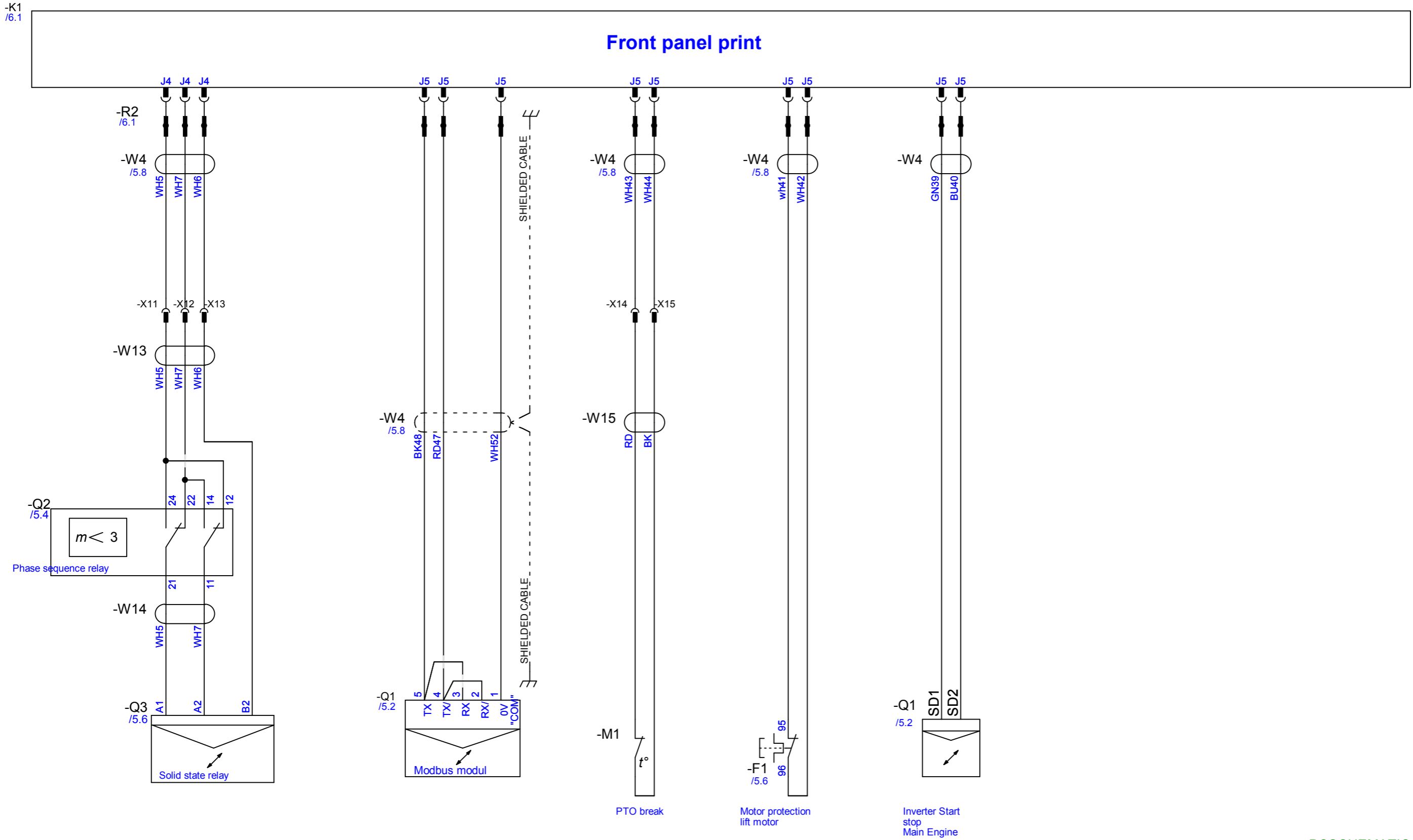

Project title: ERGO 60	Case no.:	Project rev.:	Page 7
Customer:	DCC: &FS		Scale: 1:1
Page title: Diagram	Dwg. no.: 03	Page rev.: 01	Previous page: 6
File name: 35.060-10.03.04_external_use	Eng. (proj/page): CE / CE	Last print: 22-12-2017	Next page: 8
Page ref.:	Appr. (date/init):	Last edit: 21-12-2017	Total no. of pages: 25

-K1
/6.1
/7.1

Front panel print

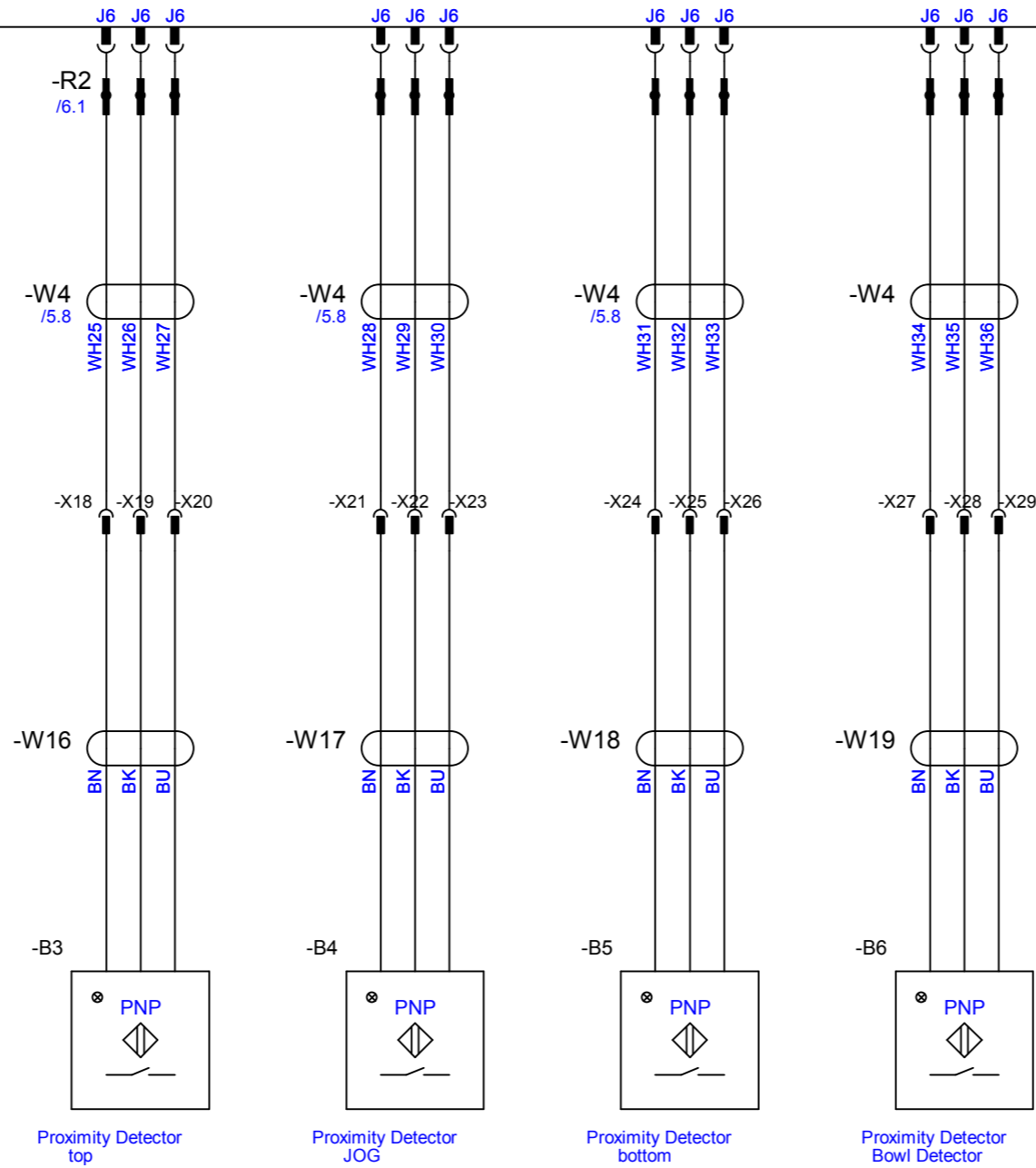

Project title: ERGO 60	Case no.:	Project rev.:	Page 8
Customer:	DCC: &FS		Scale: 1:1
Page title: Diagram	Dwg. no.: 04	Page rev.:	Previous page: 7
File name: 35.060-10.03.04_external_use	Eng. (proj/page): CE / CE	Last print: 22-12-2017	Next page: 9
Page ref.:	Appr. (date/init):	Last edit: 21-12-2017	Total no. of pages: 25

Lists

Component	Article	Type	Description	Position
				/5.6
-B1	AE140-512M	Guard detection		/6.6
-B2	AE140-512M	Guard detection		/6.7
-B3	AE140-86.1M	Magnet induktiv sensor		/8.3
-B4	AE140-86.1M	Magnet induktiv sensor		/8.4
-B5	AE140-86.1M	Magnet induktiv sensor		/8.5
-B6	R20E-501.7	Magnet induktiv sensor		/8.6
-F1	CE61-420.5	Safety relay		/5.6
-K1	AE140-561	Print for VL4 panel		/6.1
-K3	AE140-420	Safety relay		/6.5
-M1	WE61-85	Main motor incl. PTO		/5.2
-M2	WE61-86m	Lift motor		/5.6
-Q1	CE61-601	Inverter 3kW		/5.2
-Q2	CE61-420.4	Phase sequence relay		/5.4
-Q3	AE140-420.3	Solid state relay		/5.6
-R1	AE140-601.1	RFI Filter		/5.2
-R2	AE140-601.8	Permanent magnet		/6.1
-S1	CE61-174	Emergency in front panel		/6.2
-S2	CE61-173.1M	Micro switch CE		/6.3
-T1	CE61-414	24VDC Power supply 400VSC/24VDC		/5.7
-W1	WE61-194.1M	POWER		/5.1
-W4	WE61-542.5	24VDC main circuit cable		/5.8

PCSCHMATIC Automation



From	Cable	To	Type
POWER L1 /5.1	-W1 BK1	K1 2 /5.1	POWER
POWER L2 /5.1	-W1 BK2	K1 4 /5.1	POWER
POWER L3 /5.1	-W1 BK3	K1 6 /5.1	POWER
POWER PE /5.1	-W1 YE/GN	K1 8 /5.1	POWER
-Q1 L1 /5.2	-W2 BK1	-Q2 A2 /5.4	Cable drive to electrical box
-Q1 L2 /5.2	-W2 BK2	-Q3 L2 /5.6	Cable drive to electrical box
-Q1 L3 /5.2	-W2 BK3	-Q3 L3 /5.6	Cable drive to electrical box
-R1 8 /5.2	-W2 YE/GN	/5.6	Cable drive to electrical box
-Q3 T1 /5.5	-W3 BK 1	-F1 1 /5.5	Conductor
-Q3 T2 /5.6	-W3 BK 2	-F1 3 /5.6	Conductor
-Q3 T3 /5.6	-W3 BK 3	-F1 5 /5.6	Conductor
-R2 0 /6.1	-W4 BK17	-S1 1 /6.1	Conductor, emergency stop to the front panel
-R2 0 /6.2	-W4 BU19	-S1 1 /6.2	Conductor, emergency stop to the front panel
-R2 0 /6.2	-W4 GN20	-S1 2 /6.2	Conductor, emergency stop to the front panel
-R2 0 /6.2	-W4 RD18	-S1 2 /6.1	Conductor, emergency stop to the front panel
-R2 0 /7.3	-W4 BK48	-Q1 5 /7.3	Shielded cable
-R2 0 /7.3	-W4 RD47	-Q1 4 /7.3	Shielded cable
-R2 0 /7.3	-W4 WH52	-Q1 1 /7.3	Shielded cable
-R2 0 /7.6	-W4 BU40	-Q1 SD2 /7.6	Conductor
-R2 0 /7.6	-W4 GN39	-Q1 SD1 /7.6	Conductor
-R2 0 /6.6	-W4 WH2	-K3 S33 /6.6	Cable to safety relay
-R2 0 /6.7	-W4 WH3	-K3 S34 /6.7	Cable to safety relay
-R2 0 /6.7	-W4 WH11	-K3 13 /6.7	Cable to safety relay
-R2 0 /6.7	-W4 WH12	-K3 14 /6.7	Cable to safety relay

PCSCHEMATIC Automation



From		Cable		To			Type	
-R2	0	/6.6	-W4	WH13	-K3	41	/6.6	Cable to safety relay
-R2	0	/6.6	-W4	WH14	-K3	42	/6.6	Cable to safety relay
-R2	0	/6.5	-W4	WH15	-K3	A1	/6.5	Cable to safety relay
-R2	0	/6.6	-W4	WH16	-K3	A2	/6.6	Cable to safety relay
-R2	0	/7.1	-W4	WH5	-X11	0	/7.1	
-R2	0	/7.1	-W4	WH6	-X13	0	/7.1	
-R2	0	/7.1	-W4	WH7	-X12	0	/7.1	
-T1	V+	/5.7	-W4	WH01	-R2	0	/6.1	24VDC main circuit cable
			-W4	WH04	-R2	0	/6.1	24VDC main circuit cable
-R2	0	/6.3	-W4	WH21	-X1	0	/6.3	Cable micro switch
-R2	0	/6.4	-W4	WH22	-X2	0	/6.4	Cable micro switch
-R2	0	/6.4	-W4	WH23	-X3	0	/6.4	Cable micro switch
-R2	0	/6.4	-W4	WH24	-X4	0	/6.4	Cable micro switch
-R2	0	/8.3	-W4	WH25	-X18	0	/8.3	Cable PNP top
-R2	0	/8.3	-W4	WH26	-X19	0	/8.3	Cable PNP top
-R2	0	/8.3	-W4	WH27	-X20	0	/8.3	Cable PNP top
-R2	0	/8.4	-W4	WH28	-X21	0	/8.4	Cable PNP JOG
-R2	0	/8.4	-W4	WH29	-X22	0	/8.4	Cable PNP JOG
-R2	0	/8.4	-W4	WH30	-X23	0	/8.4	Cable PNP JOG
-R2	0	/8.5	-W4	WH31	-X24	0	/8.5	Cable PNP bund
-R2	0	/8.5	-W4	WH32	-X25	0	/8.5	Cable PNP bund
-R2	0	/8.5	-W4	WH33	-X26	0	/8.5	Cable PNP bund
-R2	0	/8.6	-W4	WH34	-X27	0	/8.6	Cable PNP Bowl
-R2	0	/8.6	-W4	WH35	-X28	0	/8.6	Cable PNP Bowl
-R2	0	/8.6	-W4	WH36	-X29	0	/8.6	Cable PNP Bowl
-R2	0	/7.5	-W4	WH42	-F1	96	/7.5	Cable termoe relay
-R2	0	/7.5	-W4	wh41	-F1	95	/7.5	Cable termoe relay
-R2	0	/7.4	-W4	WH43	-X14	0	/7.4	Cable to PTO

PCSCHEMATIC Automation



From			Cable		To			Type
-R2	0	/7.4	-W4	WH44	-X15	0	/7.4	Cable to PTO
-Q1	U	/5.2	-W5	BK1	-M1	U	/5.2	Cable main motor
-Q1	V	/5.2	-W5	BK2	-M1	V	/5.2	Cable main motor
-Q1	W	/5.2	-W5	BK3	-M1	W	/5.2	Cable main motor
-Q1	PE	/5.2	-W5	YE/GN	-M1	PE	/5.2	Cable main motor
-F1	2	/5.5	-W6	BK 1	-M2	U	/5.5	Cable for lift motor
-F1	4	/5.6	-W6	BK 2	-M2	V	/5.6	Cable for lift motor
-F1	6	/5.6	-W6	BK 3	-M2	W	/5.6	Cable for lift motor
		/5.6	-W6	YE/GN	-M2	PE	/5.6	Cable for lift motor
-X1	0	/6.3	-W8	BK	-S2	22	/6.3	Cable micro switch
-X2	0	/6.4	-W8	GN	-S2	21	/6.3	Cable micro switch
-X4	0	/6.4	-W8	RD	-S2	13	/6.4	Cable micro switch
-X3	0	/6.4	-W8	WH	-S2	14	/6.4	Cable micro switch
-K3	S22	/6.6	-W9	RD	-X6	0	/6.6	Conductor
-K3	S11	/6.6	-W9	YE	-X5	0	/6.6	Conductor
-K3	S21	/6.7	-W10	BK	-X10	0	/6.7	Conductor
-K3	S12	/6.7	-W10	GN	-X9	0	/6.7	Conductor
-X8	0	/6.6	-W11	BK	-B1	3	/6.6	Cable bowl detection
-X6	0	/6.6	-W11	BN	-B1	2	/6.6	Cable bowl detection
-X5	0	/6.6	-W11	BU	-B1	1	/6.6	Cable bowl detection
-X7	0	/6.6	-W11	GY	-B1	4	/6.6	Cable bowl detection



From		Cable		To		Type	
-X8	0	/6.6	-W12 BK	-B2	2	/6.7	Cable bowldetection
-X9	0	/6.7	-W12 BN	-B2	3	/6.7	Cable bowldetection
-X10	0	/6.7	-W12 BU	-B2	4	/6.7	Cable bowldetection
-X7	0	/6.6	-W12 GY	-B2	1	/6.7	Cable bowldetection
-X11	0	/7.1	-W13 WH5	-Q2	12	/7.1	Conductor
-X13	0	/7.1	-W13 WH6	-Q3	B2	/7.1	Conductor
-X12	0	/7.1	-W13 WH7	-Q2	14	/7.1	Conductor
-Q2	21	/7.1	-W14 WH5	-Q3	A1	/7.1	Conductor
-Q2	11	/7.1	-W14 WH7	-Q3	A2	/7.1	Conductor
-X15	0	/7.4	-W15 BK	-M1	2	/7.4	PTO kabel
-X14	0	/7.4	-W15 RD	-M1	1	/7.4	PTO kabel
-X19	0	/8.3	-W16 BK	-B3		/8.3	PNP Sensor cable top
-X18	0	/8.3	-W16 BN	-B3		/8.3	PNP Sensor cable top
-X20	0	/8.3	-W16 BU	-B3		/8.3	PNP Sensor cable top
-X22	0	/8.4	-W17 BK	-B4		/8.4	PNP Sensor cable JOG
-X21	0	/8.4	-W17 BN	-B4		/8.4	PNP Sensor cable JOG
-X23	0	/8.4	-W17 BU	-B4		/8.4	PNP Sensor cable JOG
-X25	0	/8.5	-W18 BK	-B5		/8.5	PNP Sensor cable bottom
-X24	0	/8.5	-W18 BN	-B5		/8.5	PNP Sensor cable bottom
-X26	0	/8.5	-W18 BU	-B5		/8.5	PNP Sensor cable bottom
-X28	0	/8.6	-W19 BK	-B6		/8.6	PNP Sensor cable bowl

PCSCHEMATIC Automation



Page no.	Title	Page remarks	Revision	Last edit
1	front page			28-07-2017
2	Indeks			28-12-2016
3	Table of contents			22-12-2017
4	Diagram			21-12-2017
	Diagram			
5	Diagram			21-12-2017
6	Diagram			21-12-2017
7	Diagram		01	21-12-2017
8	Diagram			21-12-2017
	Lists			
9	Parts List			21-12-2017
10	Component list			21-12-2017
11	Cable list			21-12-2017
16	Comments (log)			22-12-2017

PCSCHEMATIC Automation



Page no.	Title	Page remarks	Revision	Last edit
	Arrangement			
18	Component placement			22-12-2017
19	Cable connection			22-12-2017
	PCB diagram			
20	Diagram			22-12-2017
21	Diagram			28-12-2016

PCSCHEMATIC Automation



Project title: ERGO 60	Case no.:	Project rev.:	Page 17
Customer:			Scale: 1:1
Page title: Comments (log)	Dwg. no.:	Page rev.:	Previous page: 16
File name: 35.060-10.03.04_external_use	Eng. (proj/page): CE	Last print: 22-12-2017	Next page: 18
Page ref.:	Appr. (date/init):	Last edit: 22-12-2017	Total no. of pages: 25

Arrangement

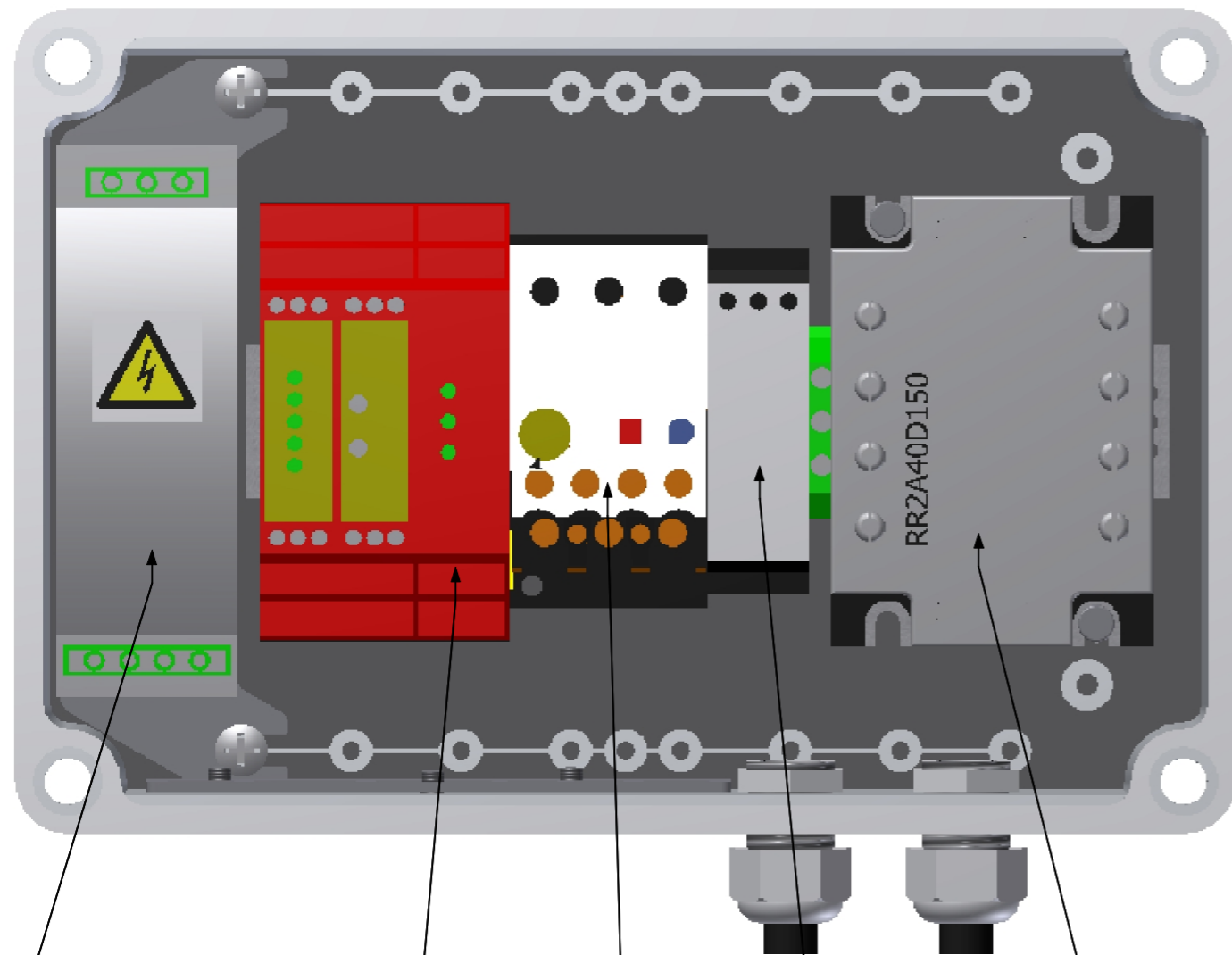

400VAC/24VDC
power supply
Part no. CE61-414

Safety relay
Part no. AE140-420

Safety relay
part no. AE140-420.4

Phase sequence relay
part no. CE61-420.4

Solid state relay
part no. CE140-420.3

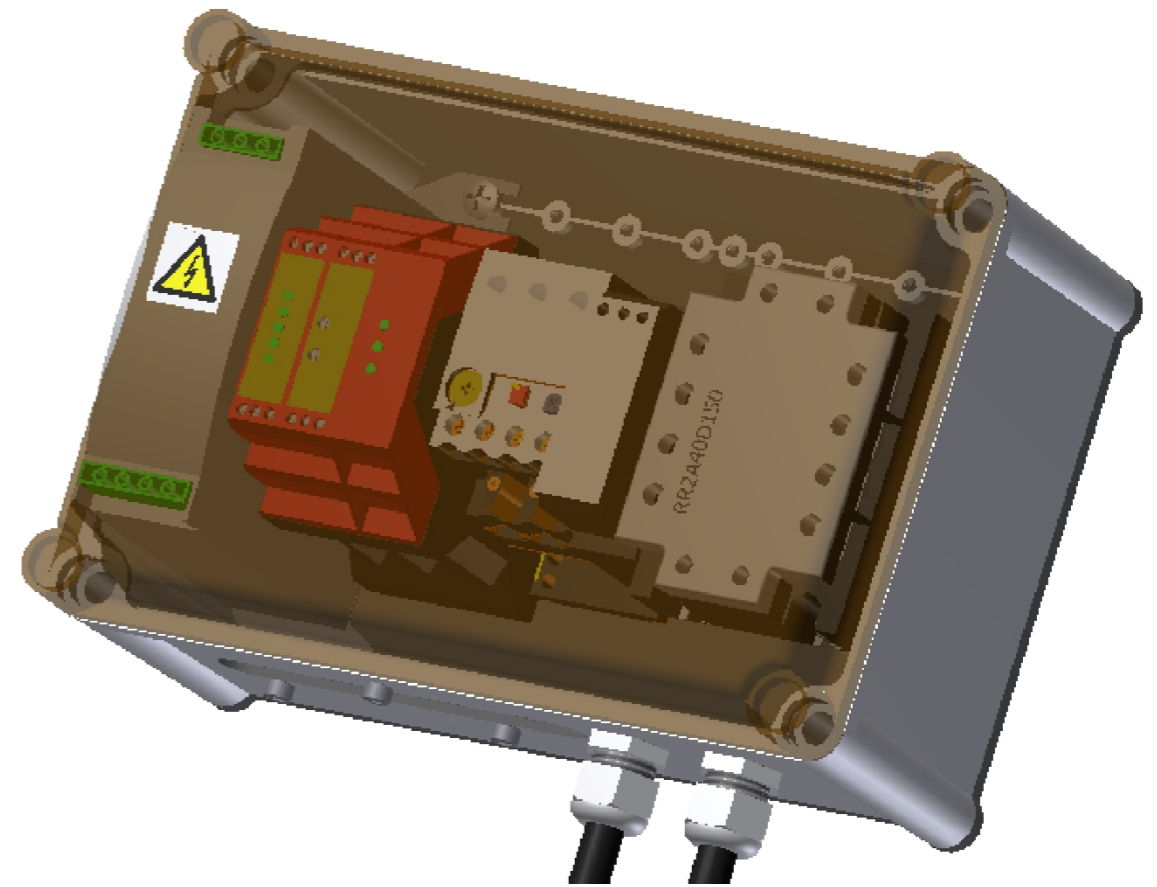

Project title: ERGO 60	Case no.:	Project rev.:	Page 18
Customer:	DCC: &LU		Scale: 1:1
Page title: Component placement	Dwg. no.: 05	Page rev.:	Previous page: 17
File name: 35.060-10.03.04_external_use	Eng. (proj/page): CE / CE	Last print: 22-12-2017	Next page: 19
Page ref.:	Appr. (date/init):	Last edit: 22-12-2017	Total no. of pages: 25

