

Varimixer

# ERGO140

**ERGONOMIC HANDLING** Separate removal of bowl and tools. The taller frame allows you to lower the bowl below the tool, so each of them can be removed separately, increasing efficiency.

**CONTROL PANEL** Choose between variable speed control, fixed speeds or up to 24 programs with their own processes. All operations are controlled from the intuitive, angled touch panel control panel. The panel is easy to clean and is dustproof and waterproof.

**REMOVABLE SAFETY GUARD** The removable safety guard is made of stainless steel and is easy to remove and dishwasher safe.

**ERGONOMIC WORKING HEIGHT** All work at Varimixer ERGO is done with a straight back. There is unhindered access to changing tools at the correct ergonomic working height.

**AUTOMATIC BOWL LOWERING** It is not necessary to watch the mixing process. When the time is up, the control system lowers the bowl, so the tools can drip off directly into the bowl.

**LIFT FOR EASY HANDLING** Even the largest bowls can be easily and ergonomically lifted using an electronic bowl lift, which also ensures correct working height during filling and emptying. Choose from several models - or choose a manual bowl truck for transport only.

**HYGIENIC AND EASY TO CLEAN** All surfaces and accessories are made of stainless steel, and the design ensures the best possible hygiene and very easy cleaning. Varimixer ERGO can be washed in accordance with the IP53 standard, and can be upgraded to either a marine version or IP54 cleaning, with a waterproof stainless steel mixer head.

**NO HEAVY LIFTING** The bowl is wheeled into place between the two arms. The bowl is automatically centered and locked into position, when raised.



**VARIMIXER ERGO 140 OPTIONS – MODELS**



Stainless steel



Marine version, stainless steel

**OPTIONS – IP54**



Waterproof planetary head, stainless steel, IP54



Air ventilation - Double layer protected, stainless steel, IP54

**OPTIONS – SAFETY GUARDS**



Removable safety guard in stainless steel. CE-certified

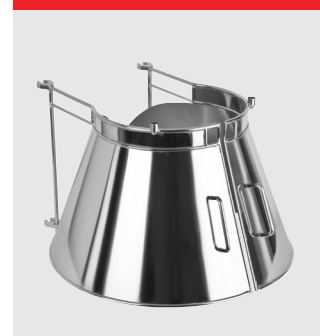

Removable splash guard in stainless steel. CE-certified

**VARIMIXER ERGO 140 STANDARD TOOLS – A-EQUIPMENT 140L**



Whip with double pin, hook with double pin, beater with double pin and bowl 140 liter in stainless steel.

**VARIMIXER ERGO 140 STANDARD TOOLS – B-EQUIPMENT 140/80L**



Whip, hook, beater and bowl 140/80 liter in stainless steel.

## OPTION - TOOLS



Tool rack, 127 cm



Wing whip with double pin, stainless steel



Whip with double pin, with thinner wires, stainless steel



Beater with double pin, aluminium



Beater with double pin, stainless steel



Hook with double pin, stainless steel



Powder mixer with double pin, stainless steel



Automatic scraper, stainless steel.



Bowl with bottom draining pipe, stainless steel

## EQUIPMENT - TRANSPORTION



Bowl truck



Easylift 80-140



Maxilift Inox



Wheels for bowl

## VARIMIXER ERGO140 STANDARD

Stainless steel
1 bowl 140 liter in stainless steel
1 beater in aluminium with double pin
1 center reinforced whip with double pin
Removable safety guard in stainless steel – CE-certified
Separate removal of bowl and tool
Digital timer and emergency stop
Voltage: 3 ph, 400V, 50 Hz with ground. 7.500 W

## VARIMIXER ERGO140 STANDARD TECHNICAL DATA

Volume	140 l
Effect	7.500 W
Voltage*	400 V
Residual current devices (RCD):	
Industrial environment	HPFI type A-SI or PFI type B
Light industry/domestic	HPFI type A-SI
Net weight	500 kg
Shipping gross weight	550 kg
H x W x L (Shipping dimensions)	2370 x 980 x 1440 mm
H x W x L (Product dimensions)	2057 x 863 x 1372 mm
HS Code	84381010
Vol. m <sup>3</sup>	3.34 m <sup>3</sup>
Ldm	0.60
Variable speed	47 – 259 RPM
Phases	3 ph
IP code	IP53
IP code upgrade	IP54

\*Other voltage power supply are available upon request in the range of 200 to 480 V. All standard and marine mixers are available in 50 and 60 Hz.

## VARIMIXER ERGO140 MARINE VERSION - IP CODE: IP54

Stainless steel execution, water cover at air ventilation, slotted free screws, full welded stainless steel knees, gasket at the rear plate, gasket at front panel and top cover. Complies with USPHS.

Voltage: 3 ph, 440V, 50 Hz with ground. 7.500 W  
3 ph, 480V, 50 Hz with ground. 7.500 W

## DIMENSIONS

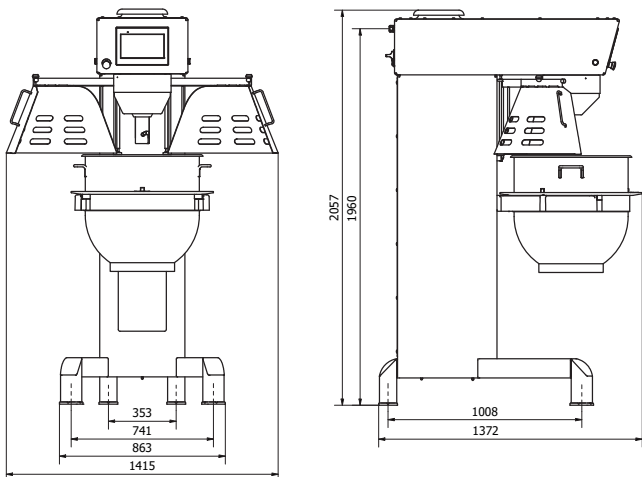

# Varimixer

Varimixer A/S  
Elementfabrikken 9  
DK-2605 Brøndby  
P: +45 4344 2288  
E: info@varimixer.com  
www.varimixer.com

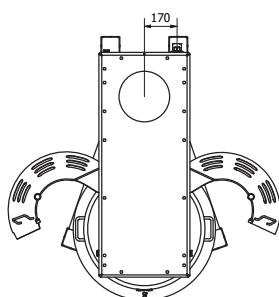

## CAPACITIES

Tools	Product		Special attention
Whip	Egg Whites	7 l	
	Whipped cream	35 l	
	Buttercream frosting	63 l	+ □
	Layer Cake Sponges	37 kg	
	Mayonnaise	56 l	+
Beater	Mashed potatoes	76 kg	+
	Cakes	77 kg	
	Icing, Fondant	56 kg	+
	Herb Butter	49 kg	+ □
	Meatball / Vegan meatball mix	84 kg	+
Hook	Pasta, noodles (50%AR)	63 kg	●
	Dough, wheat (50%AR)	70 kg	●
	Dough, wheat (55%AR)	76 kg	●
	Dough, wheat (60%AR)	91 kg	●
	Dough, whole wheat (70%AR)	85 kg	
	Dough, rye bread	112 kg	+
	Dough, sourdough bread	85 kg	
	Dough, gluten free	66 kg	

The capacity chart shows the maximum capacity for the specific machine. The testing has been conducted with standard equipment. Therefore, the use of special tools, can result in a different outcome. Always start the machine at the lowest speed. Increase the speed subsequently, taking the product being mixed into account.

Symbols explainer - Recommended actions:

- + = Apply scraper, for the best and most efficient result
- = Always make sure the ingredients are room temperature/soft. If not, this can damage the tools.
- = Recommended to work on low speed.
- = Recommended not to go above medium speed.
- AR = Absorption Ratio (moisture in % of dry matter)

## CERTIFICATIONS

